



# Implementing Cisco Application Centric Infrastructure Workbook

**Fajar Alhafidh**  
**CCIE DC #65846**

## Contents

Cisco ACI Fabric Discovery Lab (DCloud) .....	6
1.    Fabric Discovery .....	6
2.    Configure the Basic (BGP Route Reflector) .....	6
3.    Configure the Basic (NTP) .....	6
4.    Configure the Basic (DNS).....	6
5.    Configure the Basic (OOB IP Management) .....	7
Cisco ACI Access Policies Provisioning Lab .....	8
1.    Lab Topology.....	8
2.    Configure & Verify VLAN Pool .....	9
3.    Configure Physical & Layer 3 Out Domain.....	10
4.    Configure AAEP .....	10
5.    Configure Interface Policy (CDP).....	11
6.    Configure Interface Policy (LLDP) .....	11
7.    Configure Interface Policy (Link Level) .....	11
8.    Configure Interface Policy (Port Channel).....	12
9.    Configure Access Port Policy Group .....	12
10.   Configure Port Channel Policy Group.....	12
11.   Configure Interface Profile.....	13
12.   Configure Access Port Interface Selector .....	13
13.   Configure Port Channel Interface Selector .....	13
14.   Configure Switch Profile .....	14
15.   Verify Physical Interface Status.....	15
16.   Configure Port Channel on UserX Switch .....	16
17.   Verify Port Channel Interface Status .....	16
18.   Configure VPC Policy Group.....	17
19.   Remove Port Channel Interface Selector .....	17
20.   Configure Virtual Port Channel Interface Selector.....	17
21.   Configure Port Channel on UserX Switch .....	17
22.   Verify Virtual Port Channel Interface Status.....	18
Cisco ACI Tenant Policies Provisioning Lab.....	19

1.	Lab Topology.....	19
2.	Tenant & Networking Design .....	19
3.	IP Address & VLAN Design .....	20
4.	Configure VRF .....	20
5.	Configure Bridge Domain .....	20
6.	Application Profile & EPG Design.....	21
7.	Configure Application Profile & EPG.....	22
8.	Configure Physical Domain On EPG .....	22
9.	Configure Static Ports On EPG .....	23
10.	Contract Design .....	23
11.	Configure Contract.....	23
12.	Associate Contract to EPGs.....	24
13.	Verify Connectivity Between Endpoints.....	25
	Cisco ACI External Connectivity - Layer 3 Out Lab .....	27
1.	Lab Topology.....	27
2.	Configure OSPF Layer 3 Out Over VPC .....	28
3.	Configure Contract.....	29
4.	Associate Contract to EPG .....	29
5.	Advertise Bridge Domain Subnet to L3Out.....	30
6.	Verify L3Out Configuration .....	30
	Migrating Existing Networks to Cisco ACI Using Static Port Lab .....	32
1.	Lab Topology.....	32
2.	Configure Access Port Interface Selector .....	32
3.	Configure Static Ports On EPG .....	33
4.	Remove Static Ports On EPG.....	33
	Migrating Existing Networks to Cisco ACI Using Layer 2 Out Lab .....	33
1.	Lab Topology.....	33
2.	Configure Layer 2 Out Domain.....	34
3.	Configure AAEP .....	34
4.	Configure Access Port Policy Group .....	34

5.	Configure Interface Policy Group on Existing Access Port Interface Selector	34
6.	Configure Layer 2 Out.....	35
7.	Configure Contract.....	35
8.	Associate Contract to EPGs.....	36
9.	Configure Subnet on Bridge Domain .....	36
	Cisco ACI VMM Integration Lab.....	37
1.	Lab Topology.....	37
2.	Configure & Verify VLAN Pool .....	37
3.	Configure VMM Domain.....	37
4.	Configure AAEP .....	38
5.	Configure vCenter Credential .....	38
6.	Configure vCenter.....	38
7.	Configure vSwitch.....	38
8.	Configure Access Port Policy Group .....	39
9.	Configure Access Port Interface Selector .....	39
10.	Configure VMM Domain On EPG .....	40
	Cisco ACI VRF Route Leaking Lab.....	40
1.	Lab Topology.....	40
2.	Leaking Scenario .....	41
3.	Modify Bridge Domain Configuration .....	41
4.	Configure Contract.....	41
5.	Associate Contract to EPGs.....	41
	Cisco ACI Transit Routing VRF Route Leaking Lab .....	42
1.	Lab Topology.....	42
2.	Configure L3Out External EPG .....	43
3.	Configure Contract.....	43
4.	Associate Contract to L3Out External EPG .....	44
	Cisco ACI vzAny Contract Lab .....	44
1.	Configure Contract.....	44
2.	Remove Associated Contract from EPGs .....	45

3.	Configure vzAny Contract Relation .....	45
	Cisco ACI Service Graph PBR One Arm Mode Lab .....	46
1.	Lab Topology.....	46
2.	Configure & Verify VLAN Pool .....	46
3.	Configure Physical Domain .....	46
4.	Configure Domain on Existing AAEP .....	47
5.	Modify Existing Access Port Interface Selector .....	47
6.	Configure Bridge Domain For PBR.....	47
7.	Configure L4-L7 Redirect Policy .....	47
8.	Configure L4-L7 Devices.....	48
9.	Configure L4-L7 Service Graph Template.....	48
10.	Configure L4-L7 Device Selection Policy .....	48
11.	Associate Service Graph Policy to Contract Subject .....	49



# Cisco ACI Fabric Discovery Lab (DCloud)

## 1. Fabric Discovery

- Click **Begin First Time Setup** to start the Let's Configure the Basics
- Fabric Membership > Click **Begin**
- Right click on switch & click **Register**.
- Assign the parameters from the table below:

Pod ID	Node ID	Switch Name
1	101	GCT-LF-101
1	102	GCT-LF-102
1	201	GCT-SP-201
1	202	GCT-SP-202

- Click **Submit**

## 2. Configure the Basic (BGP Route Reflector)

- BGP > Click **Begin**
- Enter these parameters:
  - AS Number : **65846**
  - Spine 1 : **101**
  - Spine 2 : **102**
- Click **Submit**

## 3. Configure the Basic (NTP)

- NTP > Click **Begin**
- Enter these parameters:
  - IP Address : **198.18.128.1**
  - Preferred : **Check**
- Click **Submit**

## 4. Configure the Basic (DNS)

- DNS > Click **Begin** > Click + On **DNS Server**
- Enter these parameters:
  - IP Address : **198.18.133.1**
  - Preferred : **Check**
  - Search Domain :
    - Name : **dcloud.cisco.com**
    - Default : Check
- Click **Submit**

## 5. Configure the Basic (OOB IP Management)

- Out Of Band Management > Review & Configure > Configure OOB IP's for selected nodes

Configure OOB IP's for selected nodes

Unconfigured Nodes

Select All

Select	ID	Name	Role
<input checked="" type="checkbox"/>	201	Leaf1	leaf
<input checked="" type="checkbox"/>	202	Leaf2	leaf
<input checked="" type="checkbox"/>	101	Spine 1	spine
<input checked="" type="checkbox"/>	102	Spine2	spine

- Enter these parameters :

IPv4 Starting Address	IPv4 Gateway	IPv6 Starting Address	IPv6 Gateway
<input type="text" value="198.18.133.203/18"/> <small>address/mask</small>	<input type="text" value="198.18.128.1"/>	<input type="text"/>	<input type="text"/>

Selected Nodes

Node Id	Name	IPv4 Address	IPv4 Gateway	IPv6 Address	IPv6 Gateway
201	Leaf1	198.18.133.203/18	198.18.128.1		
202	Leaf2	198.18.133.204/18	198.18.128.1		
101	Spine1	198.18.133.205/18	198.18.128.1		
102	Spine2	198.18.133.206/18	198.18.128.1		

- Click **Submit**

# Cisco ACI Access Policies Provisioning Lab

## 1. Lab Topology

- Access Port Interface

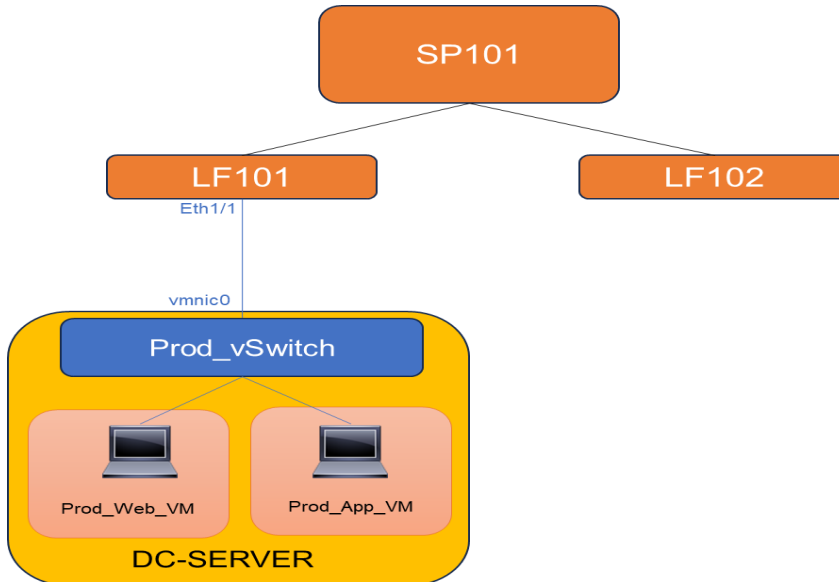

- Port Channel Interface

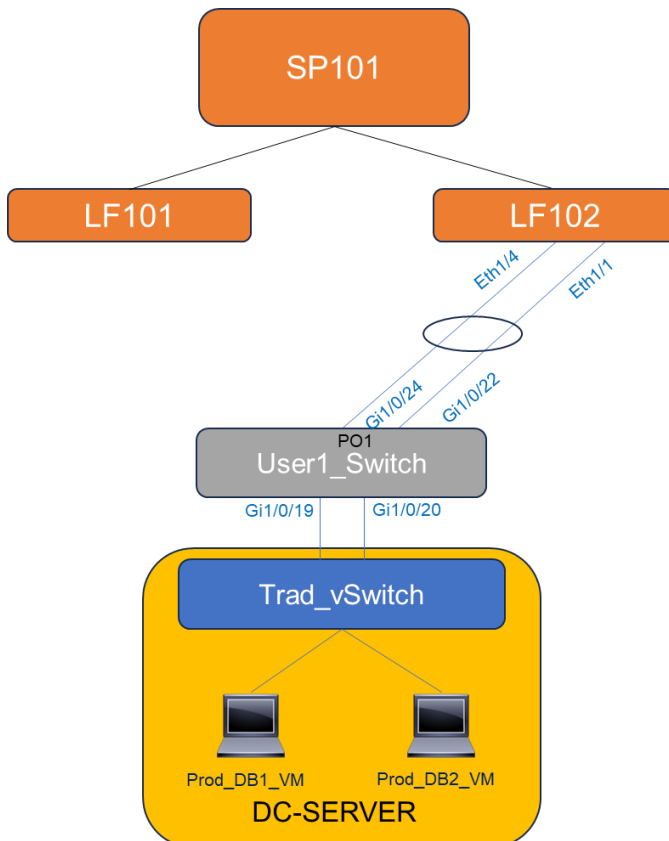

- **VPC Interface**

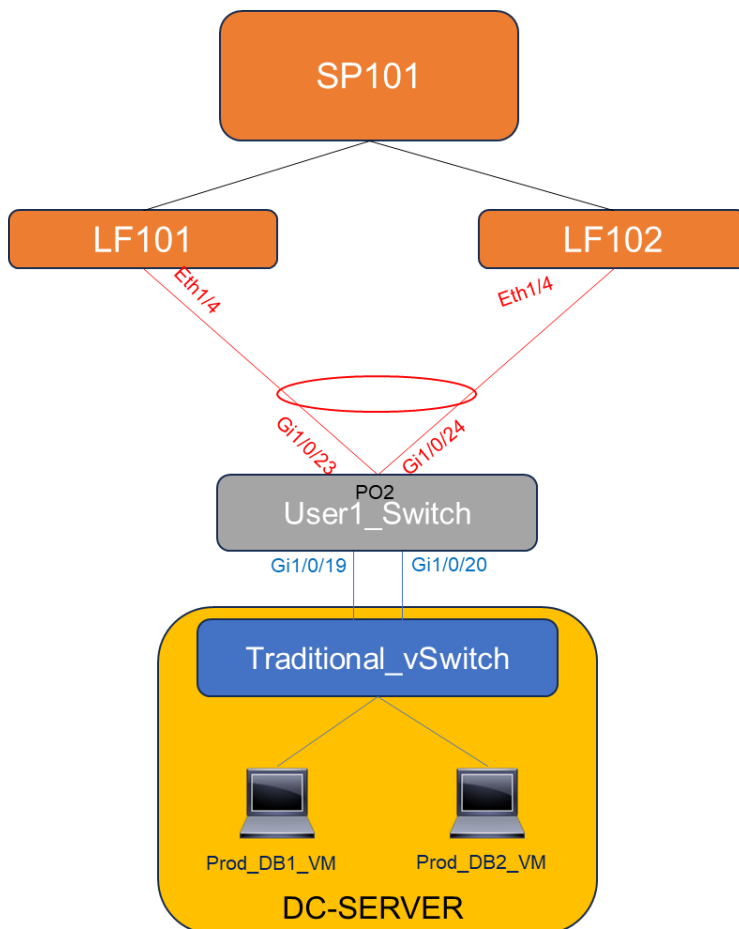

## 2. Configure & Verify VLAN Pool

- **Fabric > Access Policies > Pools > VLANs > User-Statics-VLANs-1 >**
- Verify these parameters:
  - Name : **UserX-Static-VLANs-1**
  - Allocation Mode : **Static Allocation**
  - Encap Block (Vlan Range) : **1801-1820**
- **Fabric > Access Policies > Pools > VLANs > User-Statics-VLANs-2 >**
- Verify these parameters:
  - Name : **UserX-Static-VLANs-2**
  - Allocation Mode : **Static Allocation**
  - Encap Block (Vlan Range) : **1821-1830**

### 3. Configure Physical & Layer 3 Out Domain

- **Fabric > Access Policies > Physical & External Domain > Physical Domain > Right – click > Create Physical Domain**

- Enter these parameters:

- Name : **UserX-PhysDom1**
- VLAN Pool : **UserX-Static-VLANs-1**

- Click **Submit**
- 

- **Fabric > Access Policies > Physical & External Domain > L3 Out Domain > Right – click > Create L3 Out Domain**

- Enter these parameters:

- Name : **UserX-L3OutDom2**
- VLAN Pool : **UserX-Static-VLANs-2**

- Click **Submit**

### 4. Configure AAEP

- **Fabric > Access Policies > Policies > Global > Right – Click Attachable Access Entity Profile > Create Attachable Access Entity Profile**

- Enter these parameters:

- Name : **UserX-PhysDom-AAEP**

- Click + On Domain VMM, Physical or External to be associated to interfaces:

- Domain Profile : **UserX-PhysDom1**

- Click **Update > Next > Finish**
- 

- **Fabric > Access Policies > Policies > Global > Right – Click Attachable Access Entity Profile > Create Attachable Access Entity Profile**

- Enter these parameters:

- Name : **UserX-L3OutDom-AAEP**

- Click + On Domain VMM, Physical or External to be associated to interfaces:

- Domain Profile : **UserX-L3OutDom2**

- Click **Update > Next > Finish**

## 5. Configure Interface Policy (CDP)

- **Fabric > Access Policies > Policies > Interface > CDP Interface > Right – Click > Create CDP Interface Policy**
- Policy 1
  - Name : **UserX-CDP-ON**
  - Admin State : **Enabled**
- Click **Submit**

---

- Policy 2
  - Name : **UserX-CDP-OFF**
  - Admin State : **Disabled**
- Click **Submit**

## 6. Configure Interface Policy (LLDP)

- **Fabric > Access Policies > Policies > Interface > LLDP Interface > Right – Click > Create LLDP Interface Policy**
- Policy 1
  - Name : **UserX-LLDP-ON**
  - Transmit : **Enabled**
  - Receive : **Enabled**
- Click **Submit**

---

- Policy 2
  - Name : **UserX-LLDP-OFF**
  - Transmit : **Disabled**
  - Receive : **Disabled**
- Click **Submit**

## 7. Configure Interface Policy (Link Level)

- **Fabric > Access Policies > Policies > Interface > Link Level > Right – Click > Create Link Level Interface Policy**
- Policy 1
  - Name : **UserX-1G-ON**
  - Speed : **1gbps**
- Click **Submit**

---

- Policy 2
  - Name : **UserX-10G-ON**
  - Speed : **10gbps**
- Click **Submit**

## 8. Configure Interface Policy (Port Channel)

- **Fabric > Access Policies > Policies > Interface > Port Channel > Right – Click > Create Port Channel Policy**
- Policy 1
  - Name : **UserX-LACP-ACTIVE**
  - Mode : **LACP-Active**
- Click **Submit**

---

- Policy 2
  - Name : **UserX-LACP-PASSIVE**
  - Mode : **LACP-Passive**
- Click **Submit**

---

- Policy 3
  - Name : **UserX-STATIC-ON**
  - Mode : **Static Channel – Mode On**
- Click **Submit**

## 9. Configure Access Port Policy Group

[Leaf Access Port Connected to vmnic0](#)

- **Fabric > Access Policies > Interface > Leaf Interfaces > Policy Group > Right Click Leaf Access Port > Create Leaf Access Port Policy Group**
- Enter these parameters:
  - Name : **UserX-1G\_AP\_PG**
  - CDP : **UserX-CDP-ON**
  - LLDP : **UserX-LLDP-ON**
  - Link Level : **UserX-1G-ON**
  - AAEP : **UserX-PhysDom-AAEP**
- Click **Submit**

## 10. Configure Port Channel Policy Group

[Port Channel Connected to UserX-Switch Interface Gi1/0/22 & Gi1/0/24](#)

- **Fabric > Access Policies > Interface > Leaf Interfaces > Policy Group > PC Interface > Create Port Channel Policy Group**
- Enter these parameters:
  - Name : **UserX-Switch-Po3\_PC\_PG**
  - CDP : **UserX-CDP-ON**
  - LLDP : **UserX-LLDP-OFF**
  - Link Level : **UserX-1G-ON**
  - Port-Channel : **UserX-LACP-ACTIVE**

- AAEP : UserX-PhysDom-AAEP
  - Click **Submit**
- 

## 11. Configure Interface Profile

### Interface Profile for Leaf 101, Leaf 102 & Leaf 101-102

- **Fabric > Access Policies > Interface > Leaf Interfaces > Right Click Profiles > Create Leaf Interface Profile**
- Profile 1:
  - Name : UserX-LF101-IPF
- Click **Submit**
- Profile 2:
  - Name : UserX-LF102-IPF
- Click **Submit**
- Profile 3:
  - Name : UserX-LF101-102-IPF
- Click **Submit**

## 12. Configure Access Port Interface Selector

### Interface Selector for Access Port Interface from Leaf 101 Connected to DC1-SERVER2

- **Fabric > Access Policies > Interface > Leaf Interfaces > Profiles > UserX-LF101-IPF > Click + on Interface Selector**
- Selector:
  - Name : L101\_Eth1-37
  - Description : Connected to ESXi\_vmnic0
  - Interface ID : 1/37
  - Interface Policy Group : UserX-1G\_AP\_PG
- Click **Submit**

## 13. Configure Port Channel Interface Selector

### Interface Selector for Port Channel Interface from Leaf 102 Connected to UserX-Switch Interface Gi1/0/22 & Gi1/0/24

- **Fabric > Access Policies > Interface > Leaf Interfaces > Profiles > UserX-LF102-IPF > Click + on Interface Selector**
- Selector:
  - Name : UserX-Switch-Po3

- Description : **Connected to UserX Switch Po1**
- Interface ID : **1/37**
- Interface Policy Group : **UserX-Switch-Po3\_PC\_PG**

- Click **Submit**

[Add More Interface to the Port Channel Policy](#)

- **Fabric > Access Policies > Interface > Leaf Interfaces > Profiles > UserX-LF102-IPF > UserX-Switch-Po1** Click + on Port Blocks

- Interface ID : **1/40**

- Click **Submit**

## 14. Configure Switch Profile

[Switch Profile for Leaf 101](#)

- **Fabric > Access Policies > Switches > Leaf Switches > Profiles > Right-Click > Create Leaf Profile**

- Profile 1:

- Name : **UserX-LF101-SPF**

- Click + On Leaf Selector

- Leaf Name : **LF101**
- Block : **101**

- Click Next & Select Interface Selector Profiles

- Interface Selector Profiles : **UserX-LF101-IPF**

- Click **Submit**

[Switch Profile for Leaf 102](#)

- **Fabric > Access Policies > Switches > Leaf Switches > Profiles > Right-Click > Create Leaf Profile**

- Profile 1:

- Name : **UserX-LF102-SPF**

- Click + On Leaf Selector

- Leaf Name : **LF102**

- Block : **102**
- Click Next & Select Interface Selector Profiles
  - Interface Selector Profiles : **UserX-LF102-IPF**
- Click **Submit**

Switch Profile for Leaf 101 & 102

- **Fabric > Access Policies > Switches > Leaf Switches > Profiles > Right-Click > Create Leaf Profile**
- Profile 1:
  - Name : **UserX-LF101-102-SPF**
- Click + On Leaf Selector
  - Leaf Name : **LF101-102**
  - Block : **101-102**
- Click Next & Select Interface Selector Profiles
  - Interface Selector Profiles : **UserX-LF101-102-IPF**
- Click **Submit**

## 15. Verify Physical Interface Status

Verify Leaf 101 Interface Eth1/37 status on the ACI Fabric

- **Fabric > Inventory > Pod 1 > DC-LEAF101 > Interfaces > Physical Interface > Eth1/1 >**

Layer 1 Physical Interface Configuration - 101/eth1/1

Operational | Deployed EPGs | VLANs | Stats | QoS Stats | Health | Faults | History

Properties

Description is editable from the Interface Configuration Table, the Interface Selector, or the Override Policy

- Interface: eth1/1
- Description:
- Admin State: Up
- Usage: EPG
- Oper Speed: 1 Gbps
- Oper State: Up
- Oper State Reason: connected
- Backplane Mac: 54:88:DE:90:21:51
- Last Link St Change: 2024-02-05T22:30:05.268-06:00
- Oper Router Mac: 00:00:00:00:00:00
- Oper Mdiix: Auto
- Access VLAN: unknown
- Native VLAN: unknown
- Reset Counter: 18

- Make sure the Admin State & Oper State is Up.

## 16. Configure Port Channel on UserX Switch

### [Port Channel 1 Configuration Script](#)

```
interface GigabitEthernet1/0/22
  channel-group 1 mode active
interface GigabitEthernet1/0/24
  channel-group 1 mode active
```

## 17. Verify Port Channel Interface Status

### [Verify Port Channel Interface status on the ACI Fabric](#)

- **Fabric > Inventory > Pod 1 > DC-LEAF102 > Interfaces > PC Interface > PoXX-UserX-Switch-Po1\_PC\_PG**

Aggregated Interface - po21-User1-Switch-Po1\_PC\_PG

Operational | VLANs | Stats | Health | Faults | History

Properties

Description is editable from the Interface Configuration Table, the Interface Selector, or the Override Policy

Pc Id: po21  
Description:  
Last Bundle Mbr: eth1/1  
Protocol: lacp-active  
Speed: 1 Gbps  
Layer: Switched  
Mode: Trunk  
Oper State: Up ●  
Oper State Reason: connected  
Allowed VLANs:  
Oper Vlan

Show Usage

- Make sure the Oper State is Up.

### [Verify Port Channel Interface status on the UserX Switch](#)

Group	Port-channel	Protocol	Ports
1	Po1(SU)	LACP	Gi1/0/22(P) Gi1/0/24(P)

UserX-Switch#

- Make sure the Port Channel Interface is Up.

## 18. Configure VPC Policy Group

[Virtual Port Channel Connected to UserX-Switch Interface Gi1/0/23 & Gi1/0/24](#)

- **Fabric > Access Policies > Interface > Leaf Interfaces > Policy Group > VPC Interface > Create VPC Interface Policy Group**
- Enter these parameters:
  - Name : **UserX-Switch-Po4-VPC\_PG**
  - CDP : **UserX-CDP-ON**
  - LLDP : **UserX-LLDP-OFF**
  - Link Level : **UserX-1G-ON**
  - Port-Channel : **UserX-LACP-ACTIVE**
  - AAEP : **UserX-L3OutDom-AAEP**
- Click **Submit**

## 19. Remove Port Channel Interface Selector

[Remove Port Channel Interface from Leaf 102 Connected to UserX-Switch Interface Gi1/0/22 & Gi1/0/24](#)

- **Fabric > Access Policies > Interface > Leaf Interfaces > Profiles> UserX-LF102-IPF > Right Click UserX-Switch-Po3 > Delete**

## 20. Configure Virtual Port Channel Interface Selector

[Interface Selector for Virtual Port Channel Interface from Leaf 101&102 Connected to UserX-Switch Interface Gi1/0/23 & Gi1/0/24](#)

- **Fabric > Access Policies > Interface > Leaf Interfaces > Profiles> UserX-LF101-102-IPF > Click + on Interface Selector**
- Selector:
  - Name : **UserX-Switch-Po4\_VPC**
  - Description : **Connected to UserX Switch Po4**
  - Interface ID : **1/40**
  - Interface Policy Group : **UserX-Switch-Po4\_VPC\_PG**
- Click **Submit**

## 21. Configure Port Channel on UserX Switch

[Port Channel 2 Configuration Script](#)

```
interface GigabitEthernet1/0/23
  channel-group 2 mode active
interface GigabitEthernet1/0/24
  channel-group 2 mode active
```



# Cisco ACI Tenant Policies Provisioning Lab

## 1. Lab Topology

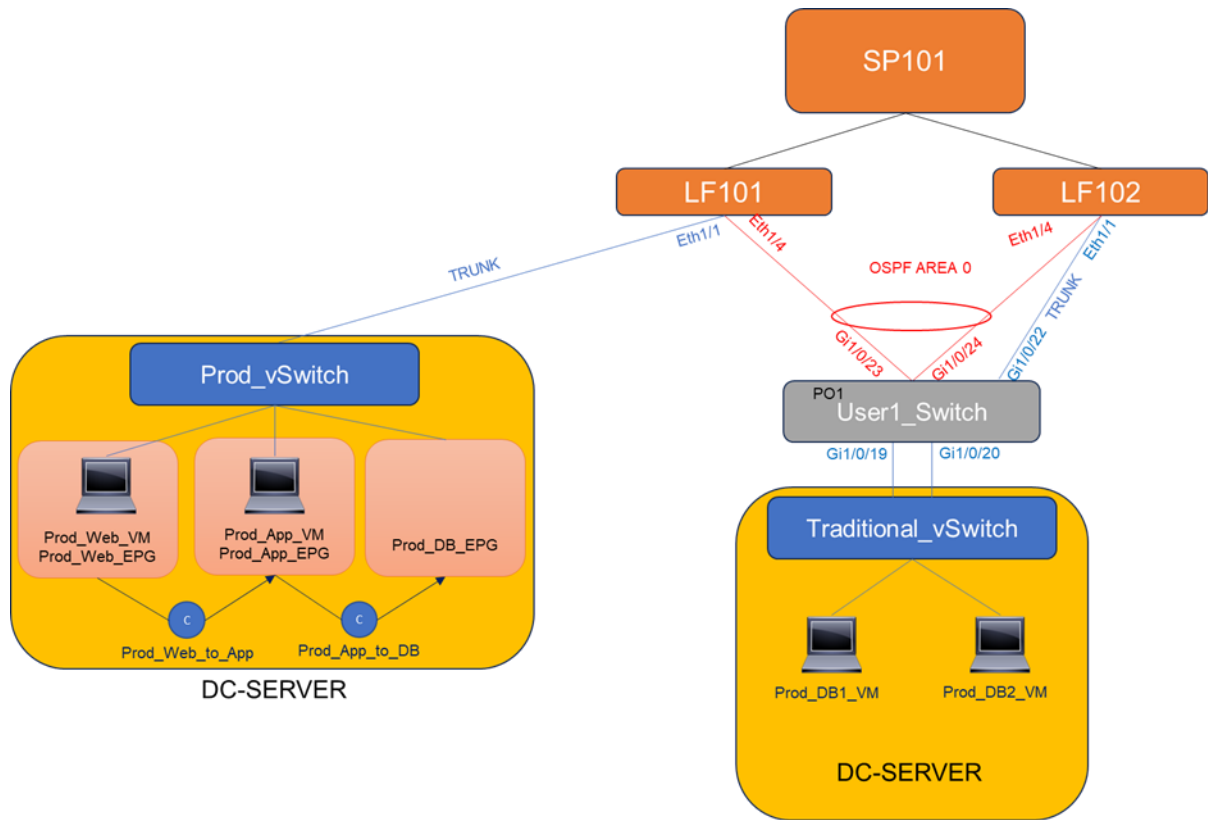

## 2. Tenant & Networking Design

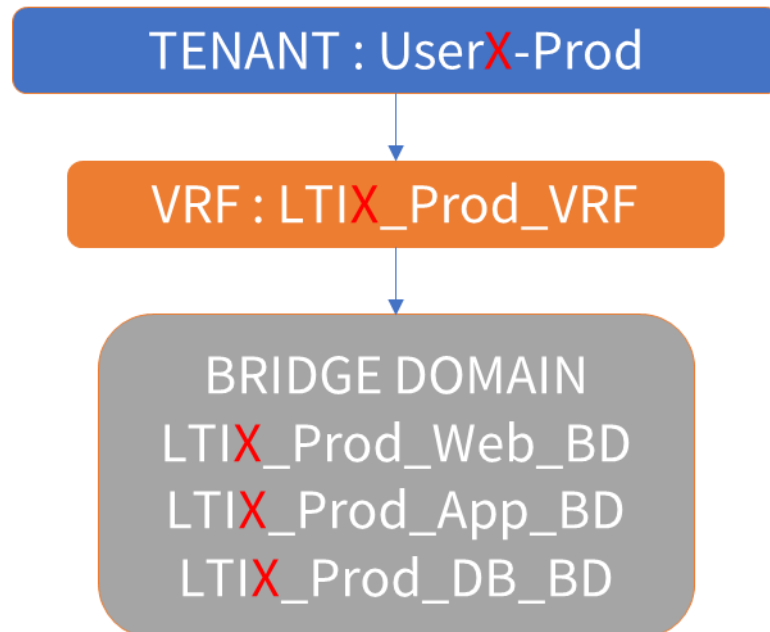

### 3. IP Address & VLAN Design

Present Number (X)	Bridge Domain Name	Bridge Domain Gateway (Y)	VM Name	VM IP Address	VLAN
1	GCT1_Prod_Web_BD	10.10.3.1/24	GCT1_Web_VM	10.10.3.10	1803
	GCT1_Prod_App_BD	10.10.4.1/24	GCT1_App_VM	10.10.4.10	1804
	GCT1_Prod_DB_BD	10.10.5.1/24	GCT1_DB1_VM GCT1_DB2_VM	10.10.5.10 10.10.5.11	1805
2	GCT2_Prod_Web_BD	10.10.6.1/24	GCT2_Web_VM	10.10.6.10	1806
	GCT2_Prod_App_BD	10.10.7.1/24	GCT2_App_VM	10.10.7.10	1807
	GCT2_Prod_DB_BD	10.10.8.1/24	GCT2_DB1_VM GCT2_DB2_VM	10.10.8.10 10.10.8.11	1808
3	GCT3_Prod_Web_BD	10.10.9.1/24	GCT3_Web_VM	10.10.9.10	1809
	GCT3_Prod_App_BD	10.10.10.1/24	GCT3_App_VM	10.10.10.10	1810
	GCT3_Prod_DB_BD	10.10.11.1/24	GCT3_DB1_VM GCT3_DB2_VM	10.10.11.10 10.10.11.11	1811
4	GCT4_Prod_Web_BD	10.10.12.1/24	GCT4_Web_VM	10.10.12.10	1812
	GCT4_Prod_App_BD	10.10.13.1/24	GCT4_App_VM	10.10.13.10	1813
	GCT4_Prod_DB_BD	10.10.14.1/24	GCT4_DB1_VM GCT4_DB2_VM	10.10.14.10 10.10.14.11	1814
5	GCT5_Prod_Web_BD	10.10.15.1/24	GCT5_Web_VM	10.10.15.10	1815
	GCT5_Prod_App_BD	10.10.16.1/24	GCT5_App_VM	10.10.16.10	1816
	GCT5_Prod_DB_BD	10.10.17.1/24	GCT5_DB1_VM GCT5_DB2_VM	10.10.17.10 10.10.17.11	1817
6	GCT6_Prod_Web_BD	10.10.18.1/24	GCT6_Web_VM	10.10.18.10	1818
	GCT6_Prod_App_BD	10.10.19.1/24	GCT6_App_VM	10.10.19.10	1819
	GCT6_Prod_DB_BD	10.10.20.1/24	GCT6_DB1_VM GCT6_DB2_VM	10.10.20.10 10.10.20.11	1820

### 4. Configure VRF

[Configure VRF Based on Participant Present Number \(X is Participant Present Number\)](#)

- **Tenant > UserX-Prod > Networking > Right-Click VRFs > Create VRF**
- Enter these parameters:
  - Name : **GCTX\_Prod\_VRF**
  - Create a Bridge Domain : **Uncheck**
- Click **Submit**

### 5. Configure Bridge Domain

[Configure L3 Bridge Domain Based on Provided Design](#)

- **Tenant > UserX-Prod > Networking > Right-Click Bridge Domain > Create Bridge Domain**
- Bridge Domain 1:

- Name : **GCTX\_Prod\_Web\_BD**
- VRF : **GCTX\_Prod\_VRF**
- Subnets/GW : **10.X.Y.1/24**

- Click **Submit**
- 

- Bridge Domain 2:
  - Name : **GCTX\_Prod\_App\_BD**
  - VRF : **GCTX\_Prod\_VRF**
  - Subnets/GW : **10.X.Y.1/24**

- Click **Submit**
- 

Configure L2 Bridge Domain Based on Provided Design

- **Tenant > UserX-Prod > Networking > Right-Click Bridge Domain > Create Bridge Domain**

- Bridge Domain 3:
  - Name : **GCTX\_Prod\_DB\_BD**
  - VRF : **GCTX\_Prod\_VRF**
  - L2 Unknown Unicast : **Flood**
  - Arp Flooding : **Check**
  - Unicast Routing : **Uncheck**

- Click **Submit**

## 6. Application Profile & EPG Design

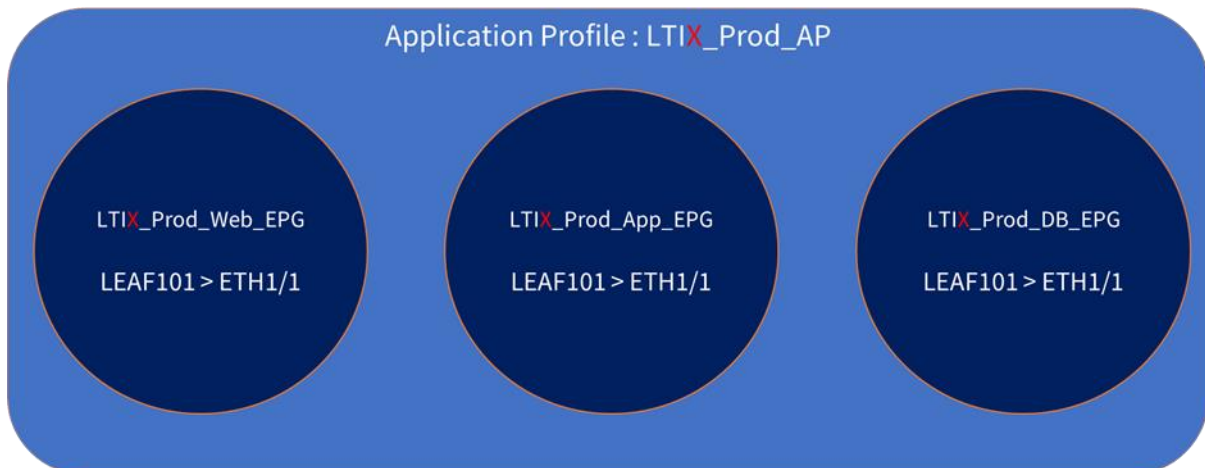

## 7. Configure Application Profile & EPG

### Configure Application Profile Based on Provided Design

- **Tenant > UserX-Prod > Networking > Right-Click Application Profile > Create Application Profile**
  - Enter the parameter:
    - Name : **GCTX\_Prod\_AP**
  - Click **Submit**
- 

### Configure Endpoint Group Based on Provided Design

- **Tenant > UserX-Prod > Application Profiles > GCTX\_Prod\_AP > Application EPGs > Right-Click > Create Application EPG**
  - Endpoint Group 1:
    - Name : **GCTX\_Prod\_Web\_EPG**
    - Bridge Domain : **GCTX\_Prod\_Web\_BD**
  - Click **Submit**
- 

- Endpoint Group 2:
    - Name : **GCTX\_Prod\_App\_EPG**
    - Bridge Domain : **GCTX\_Prod\_App\_BD**
  - Click **Submit**
- 

- Endpoint Group 3:
  - Name : **GCTX\_Prod\_DB\_EPG**
  - Bridge Domain : **GCTX\_Prod\_DB\_BD**
- Click **Submit**

## 8. Configure Physical Domain On EPG

### Configure Domain on EPGs to Connect Tenant & Fabric Policies

- **Tenant > UserX-Prod > Application Profiles > GCTX\_Prod\_AP > Application EPGs > <EPG Name> Domain > Right-Click > click Add Physical Domain Association**
  - Endpoint Group 1:
    - Application EPG : **GCTX\_Prod\_Web\_EPG**
    - Domain : **UserX-PhysDom1**
  - Click **Submit**
- 

- Endpoint Group 2:

- Name : **GCTX\_Prod\_App\_EPG**
- Domain : **UserX-PhysDom1**
- Click **Submit**

- Endpoint Group 3:
  - Name : **GCTX\_Prod\_DB\_EPG**
  - Domain : **UserX-PhysDom1**
- Click **Submit**

## 9. Configure Static Ports On EPG

[Configure Static Ports on EPGs to Allow VLAN on Leaf Interfaces](#)

- **Tenant > UserX-Prod > Application Profiles GCTX\_Prod\_AP > Application EPGs > <EPG Name> Static Ports > Right-Click > Deploy Static EPG on PC, VPC, or Interface**

EPG	Port Type	Node/Interface	VLAN	Mode
GCTX_Prod_Web_EPG	Access	101/Eth1/37	Y	Trunk
GCTX_Prod_App_EPG	Access	101/Eth1/37	Y	Trunk

- Click **Submit**

## 10. Contract Design

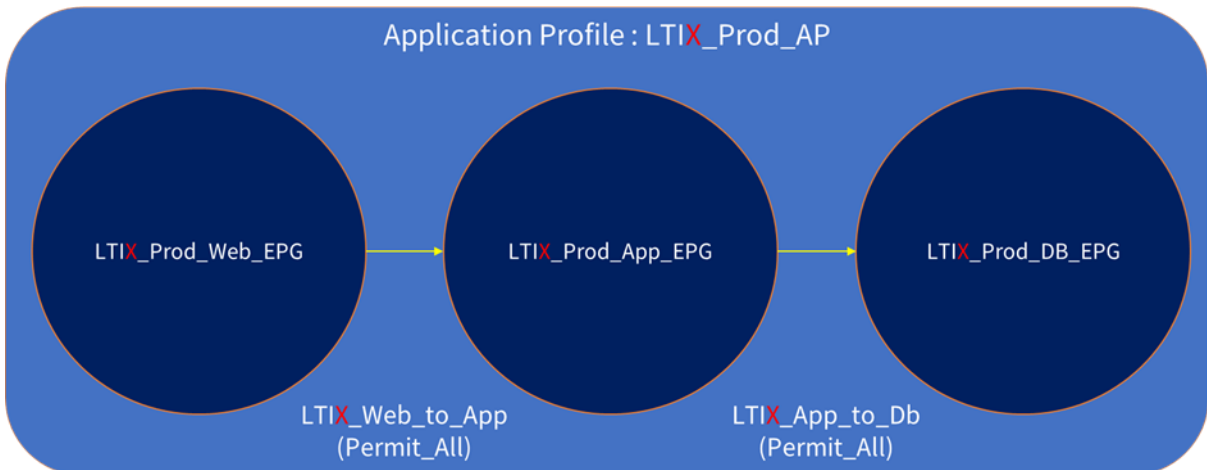

## 11. Configure Contract

[Configure Contract to allow communication from GCTX\\_Prod\\_Web\\_EPG to GCTX\\_Prod\\_App\\_EPG & GCTX\\_Prod\\_App\\_EPG to GCTX\\_Prod\\_DB\\_EPG](#)

- **Tenant > UserX-Prod > Contracts > Standard > Right-Click > Create Contract**
- Contract 1:

- Contract Name : **GCTX\_Web\_to\_App**
  - Subject Name : **GCTX\_Web\_to\_App**
  - Filter:
    - Name : **GCTX-Permit-All**
    - Ether type : **unspecified**
    - Source Port/Range : **unspecified/unspecified**
    - Destination Port/Range : **unspecified/unspecified**
  - Click **Submit**
- 
- Contract 2:
    - Contract Name : **GCTX\_App\_to\_DB**
    - Subject Name : **GCTX\_App\_to\_DB**
    - Filter:
      - Name : **GCTX-Permit-All**
      - Ether type : **unspecified**
      - Source Port/Range : **unspecified/unspecified**
      - Destination Port/Range : **unspecified/unspecified**
  - Click **Submit**

## 12. Associate Contract to EPGs

[Associate Contract to EPGs to allow communication from GCTX Prod Web EPG to GCTX Prod App EPG](#)

- **Tenant > UserX-Prod> Application Profiles > GCTX\_Prod\_AP > Application EPGs > GCTX\_Prod\_Web\_EPG > Contract > Right-Click > Add Consumed Contract**
  - Select these parameters:
    - Contract Name : **GCTX\_Web\_to\_App**
  - Click **Submit**
- 
- **Tenant > UserX-Prod> Application Profiles > GCTX\_Prod\_AP > Application EPGs > GCTX\_Prod\_App\_EPG > Contract > Right-Click > Add Provided Contract**
  - Select these parameters:
    - Contract Name : **GCTX\_Web\_to\_App**
  - Click **Submit**

[Associate Contract to EPGs to allow communication from GCTX Prod App EPG to GCTX Prod DB EPG](#)

- **Tenant > UserX-Prod> Application Profiles > GCTX\_Prod\_AP > Application EPGs > GCTX\_Prod\_App\_EPG > Contract > Right-Click > Add Consumed Contract**
- Select these parameters:
  - Contract Name : **GCTX\_App\_to\_DB**
- Click **Submit**

- **Tenant > UserX-Prod> Application Profiles > GCTX\_Prod\_AP > Application EPGs > GCTX\_Prod\_DB\_EPG > Contract > Right-Click > Add Consumed Contract**
- Select these parameters:
  - Contract Name : **GCTX\_App\_to\_DB**
- Click **Submit**

### 13. Verify Connectivity Between Endpoints

[Verify connectivity from the VMs to the Gateway](#)

- **On ESXi > Virtual Machine > (VM Names) > Console > Open Browser Console > CTRL+ALT+T > ping 10.X.Y.1**
  - **GCTX\_Prod\_Web**

The screenshot shows a terminal window titled "LTI1\_Prod\_Web" with the following content:

```

student@student-virtual-machine: ~
student@student-virtual-machine:~$
student@student-virtual-machine:~$ ping 10.1.3.1
PING 10.1.3.1 (10.1.3.1) 56(84) bytes of data:
64 bytes from 10.1.3.1: icmp_seq=1 ttl=64 time=0.337 ms
64 bytes from 10.1.3.1: icmp_seq=2 ttl=64 time=0.558 ms
64 bytes from 10.1.3.1: icmp_seq=3 ttl=64 time=0.559 ms
64 bytes from 10.1.3.1: icmp_seq=4 ttl=64 time=0.463 ms
64 bytes from 10.1.3.1: icmp_seq=5 ttl=64 time=0.458 ms
64 bytes from 10.1.3.1: icmp_seq=6 ttl=64 time=0.382 ms
64 bytes from 10.1.3.1: icmp_seq=7 ttl=64 time=0.476 ms
64 bytes from 10.1.3.1: icmp_seq=8 ttl=64 time=0.519 ms
64 bytes from 10.1.3.1: icmp_seq=9 ttl=64 time=0.496 ms
64 bytes from 10.1.3.1: icmp_seq=10 ttl=64 time=0.529 ms
64 bytes from 10.1.3.1: icmp_seq=11 ttl=64 time=0.528 ms
64 bytes from 10.1.3.1: icmp_seq=12 ttl=64 time=0.550 ms
64 bytes from 10.1.3.1: icmp_seq=13 ttl=64 time=0.525 ms
64 bytes from 10.1.3.1: icmp_seq=14 ttl=64 time=0.601 ms
  
```

- **GCTX\_Prod\_App**

```

student@student-virtual-machine: ~
PING 10.1.4.1 (10.1.4.1) 56(84) bytes of data:
64 bytes from 10.1.4.1: icmp_seq=1 ttl=64 time=0.442 ms
64 bytes from 10.1.4.1: icmp_seq=2 ttl=64 time=0.423 ms
64 bytes from 10.1.4.1: icmp_seq=3 ttl=64 time=0.465 ms
64 bytes from 10.1.4.1: icmp_seq=4 ttl=64 time=0.344 ms
64 bytes from 10.1.4.1: icmp_seq=5 ttl=64 time=0.434 ms
64 bytes from 10.1.4.1: icmp_seq=6 ttl=64 time=0.400 ms
64 bytes from 10.1.4.1: icmp_seq=7 ttl=64 time=0.524 ms
64 bytes from 10.1.4.1: icmp_seq=8 ttl=64 time=0.528 ms
64 bytes from 10.1.4.1: icmp_seq=9 ttl=64 time=0.482 ms
^C
--- 10.1.4.1 ping statistics ---
9 packets transmitted, 9 received, 0% packet loss, time 8193ms
rtt min/avg/max/mdev = 0.344/0.449/0.528/0.056 ms
student@student-virtual-machine: ~$

```

Verify that endpoint ip addresses are learned on endpoint table of cisco ACI fabric.

- **Tenant > UserX-Prod> Application Profiles > GCTX\_Prod\_AP > Application EPGs > GCTX\_Prod\_Web\_EPG > Operational**

MAC/IP	Endpoint Name	Learning Source	Hosting Server	Reporting Interface Controller Name	Encap	ESG	Policy Tags
00:50:56:9E:20:50 10.1.3.10		learned		Pod-1/Node-101/...	vlan-3		

- **Tenant > UserX-Prod> Application Profiles > GCTX\_Prod\_AP > Application EPGs > GCTX\_Prod\_App\_EPG > Operational**

MAC/IP	Endpoint Name	Learning Source	Hosting Server	Reporting Interface Controller Name	Encap	ESG	Policy Tags
00:50:56:9E:14:E1 10.1.4.10		learned		Pod-1/Node-101/...	vlan-4		

Verify connectivity between VM Web to App

- **On ESXi > Virtual Machine > (VM Names) > Console > Open Browser Console > CTRL+ALT+T > ping 10.X.Y.10**

```

LTI1_Prod_Web
Activities Terminal Kam 11:36
student@student-virtual-machine: ~
student@student-virtual-machine:~$
student@student-virtual-machine:~$ ping 10.1.4.10
PING 10.1.4.10 (10.1.4.10) 56(84) bytes of data:
64 bytes from 10.1.4.10: icmp_seq=1 ttl=63 time=0.505 ms
64 bytes from 10.1.4.10: icmp_seq=2 ttl=63 time=0.661 ms
64 bytes from 10.1.4.10: icmp_seq=3 ttl=63 time=0.590 ms
64 bytes from 10.1.4.10: icmp_seq=4 ttl=63 time=0.864 ms
64 bytes from 10.1.4.10: icmp_seq=5 ttl=63 time=0.651 ms
64 bytes from 10.1.4.10: icmp_seq=6 ttl=63 time=0.796 ms
64 bytes from 10.1.4.10: icmp_seq=7 ttl=63 time=0.773 ms
64 bytes from 10.1.4.10: icmp_seq=8 ttl=63 time=0.822 ms
64 bytes from 10.1.4.10: icmp_seq=9 ttl=63 time=0.524 ms
64 bytes from 10.1.4.10: icmp_seq=10 ttl=63 time=0.466 ms
64 bytes from 10.1.4.10: icmp_seq=11 ttl=63 time=0.582 ms
64 bytes from 10.1.4.10: icmp_seq=12 ttl=63 time=0.599 ms
64 bytes from 10.1.4.10: icmp_seq=13 ttl=63 time=0.676 ms
64 bytes from 10.1.4.10: icmp_seq=14 ttl=63 time=0.840 ms

```

# Cisco ACI External Connectivity - Layer 3 Out Lab

## 1. Lab Topology

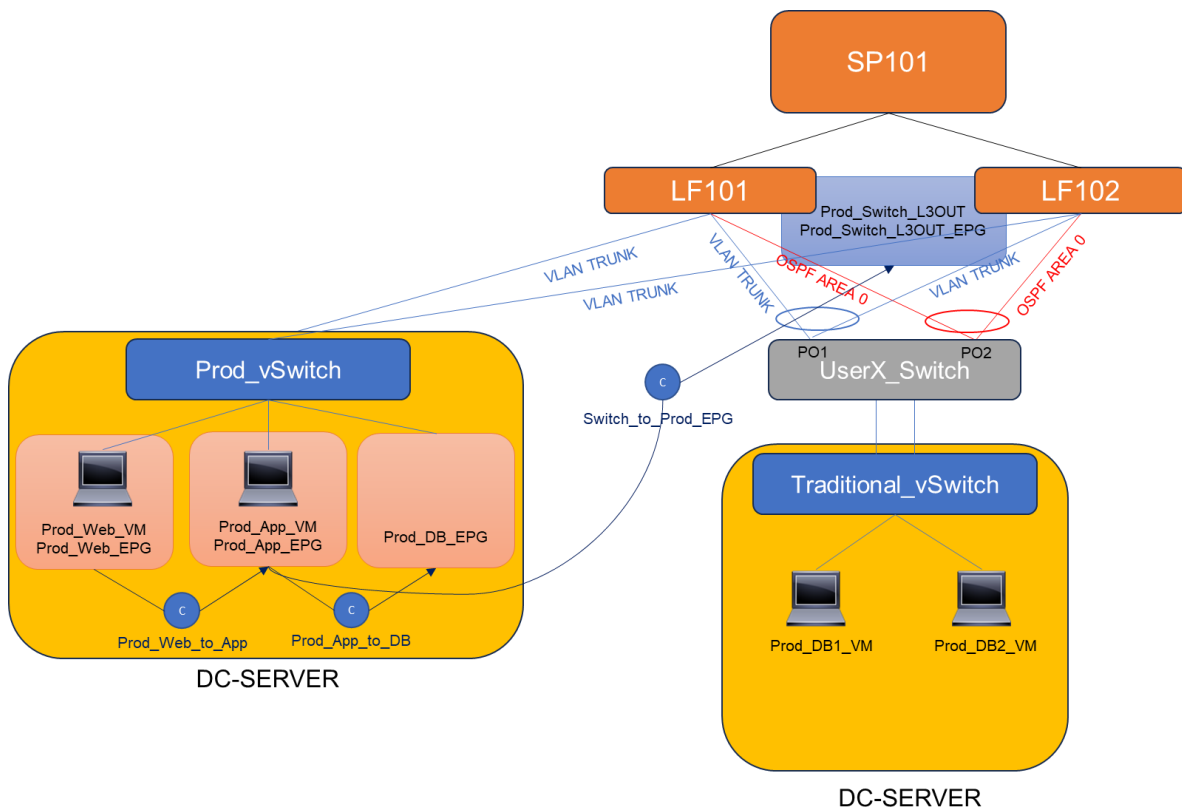

## 2. Configure OSPF Layer 3 Out Over VPC

### Configure OSPF L3Out on UserX-Prod Tenant on your created VRF to Allow Communication to UserX-Switch

- **Tenant > UserX-Prod > Networking > Right Click L3Outs > Create L3Out**
- Enter these parameters.:
  - Name : **GCTX\_Trad\_Switch\_L3OUT**
  - VRF : **GCTX\_Prod\_VRF**
  - L3 Domain : **UserX-L3OutDom2**
  - OSPF : **Checked**
  - Area ID : **0**
  - Area Type : **Regular Area**
- Click **Next to Continue**

---

### Configure Nodes & Interfaces Profile for selected node that will running the L3 Out

- Enter these parameters for Nodes and Interfaces Profile:
  - Layer 3 Interface : **SVI**
  - Layer 2 Interface : **Virtual Port Channel**
  - Address Type : **IPv4**
  - Path : **UserX-Switch\_Po4\_VPC\_PG**
  - Encap VLAN : **182X**
  - MTU : **1500**
  - Node 101 Router ID : **192.168.2X.253**
  - IP Address Primary : **192.168.2X.1/29**
  - IP Address Secondary : **192.168.2X.3/29**
  - Node 102 Router ID : **192.168.2X.254**
  - IP Address Primary : **192.168.2X.2/29**
  - IP Address Secondary : **192.168.2X.3/29**
- Click **Next to Continue**

---

### Configure OSPF Interface Policy to Change OSPF Interface Mode to Broadcast

- Select Drop Down on Policy & Create OSPF Interface Policy
- Enter these parameters:
  - Name : **GCTX\_OSPF\_Broadcast**
  - Network Type : **Broadcast**
- Click **Next to Continue**

---

### Configure L3 Out External EPG to Classify Incoming Subnet as an External EPG

- Enter these parameters for External EPG:

- Name : **GCTX\_Trad\_Switch\_L3OUT\_EPG**
- Default EPG for all External Network : **Uncheck**
- Click + On Subnet & Enter these parameters:
  - IP Address : **0.0.0.0/1**
  - External EPG Classification : **External Subnet for External EPG**
  - IP Address : **128.0.0.0/1**
  - External EPG Classification : **External Subnet for External EPG**
- Click **OK & Finish to Continue**

### 3. Configure Contract

[Configure Contract to allow communication from GCT-Prod Switch L3Out to GCTX Prod App EPG](#)

- **Tenant > UserX-Prod > Contracts > Standard > Right-Click > Create Contract**
- Contract 1:
  - Contract Name : **GCTX\_Trad\_Switch\_to\_Prod\_EPG**
  - Subject Name : **GCTX\_Trad\_Switch\_to\_Prod\_EPG**
  - Filter:
    - Name : **Permit-All**
- Click **Submit**

### 4. Associate Contract to EPG

[Associate Contract to allow communication from GCT-Prod Switch L3Out to GCTX Prod App EPG](#)

- **Tenant > UserX-Prod > Networking > L3Outs > GCTX\_Trad\_Switch\_L3Out > External EPGs > GCTX\_Trad\_Switch\_L3Out\_EPG > Contract > Add Consumed Contract**
  - Select these parameters:
    - Contract Name : **GCTX\_Switch\_to\_Prod\_EPG**
  - Click **Submit**
- 
- **Tenant > UserX-Prod > Application Profiles > GCTX\_Prod\_AP > Application EPGs > GCTX\_Prod\_App\_EPG > Contract > Right-Click > Add Provided Contract**
  - Select these parameters:
    - Contract Name : **GCTX\_Switch\_to\_Prod\_EPG**

- Click **Submit**

## 5. Advertise Bridge Domain Subnet to L3Out

[Configure Bridge Domain to advertise subnet to GCTX Trad Switch L3OUT](#)

- **Tenant > UserX-Prod > Networking > Bridge Domain > <BD Name> Policy > L3 Configuration > Click on Subnet**

- **GCTX\_Prod\_Web\_BD:**
  - Scope : **Advertise Externally**
  - Associated L3 Out : **GCTX\_Trad\_Switch\_L3OUT**

- Click **Submit**

- 
- **GCTX\_Prod\_App\_BD:**
    - Scope : **Advertise Externally**
    - Associated L3 Out : **GCTX\_Trad\_Switch\_L3OUT**

- Click **Submit**

## 6. Verify L3Out Configuration

[Verify OSPF Neighborhood On UserX-Switch](#)

- **On UserX-Switch > show ip ospf neighbor**

```
User1-Switch#show ip ospf neighbor
Neighbor ID      Pri   State           Dead Time   Address        Interface
10.1.23.253      1    FULL/BDR        00:00:35   10.1.23.1     Vlan23
10.1.23.254      1    FULL/DR         00:00:32   10.1.23.2     Vlan23
10.1.22.253      1    FULL/BDR        00:00:35   10.1.22.1     Vlan22
10.1.22.254      1    FULL/DR         00:00:34   10.1.22.2     Vlan22
10.1.21.253      1    FULL/BDR        00:00:36   10.1.21.1     Vlan21
10.1.21.254      1    FULL/DR         00:00:38   10.1.21.2     Vlan21
User1-Switch#
```

[Verify routes advertised to UserX-Switch](#)

- **On UserX-Switch > show ip route vrf GCTX**

```

User1-Switch#show ip route vrf LTI2

Routing Table: LTI2
Codes: L - local, C - connected, S - static, R - RIP, M - mobile, B - BGP
       D - EIGRP, EX - EIGRP external, O - OSPF, IA - OSPF inter area
       N1 - OSPF NSSA external type 1, N2 - OSPF NSSA external type 2
       E1 - OSPF external type 1, E2 - OSPF external type 2
       i - IS-IS, su - IS-IS summary, L1 - IS-IS level-1, L2 - IS-IS level-2
       ia - IS-IS inter area, * - candidate default, U - per-user static route
       o - ODR, P - periodic downloaded static route, H - NHRP, l - LISP
       a - application route
       + - replicated route, % - next hop override

Gateway of last resort is not set

    10.0.0.0/8 is variably subnetted, 6 subnets, 4 masks
S       10.1.0.0/16 [1/0] via 192.168.32.1
O E2    10.1.7.0/24 [110/20] via 10.1.22.2, 00:03:38, Vlan22
         [110/20] via 10.1.22.1, 00:03:38, Vlan22

```

### Verify connectivity between VM App to DB

- **On ESXi > Virtual Machine > (VM Names) > Console > Open Browser Console > CTRL+ALT+T > ping 10.X.Y.10 & 10.X.Y.11**

The screenshot shows a terminal window titled "LTI2\_Prod\_App" with a terminal icon. The terminal output shows the following commands and results:

```

student@student-virtual-machine: ~
ping: 10.1.8.10: name or service not known
student@student-virtual-machine:~$ ping 10.1.8.10
PING 10.1.8.10 (10.1.8.10) 56(84) bytes of data:
64 bytes from 10.1.8.10: icmp_seq=1 ttl=63 time=0.541 ms
64 bytes from 10.1.8.10: icmp_seq=2 ttl=63 time=0.761 ms
^C
--- 10.1.8.10 ping statistics ---
2 packets transmitted, 2 received, 0% packet loss, time 1030ms
rtt min/avg/max/mdev = 0.541/0.651/0.761/0.110 ms
student@student-virtual-machine:~$ ping 10.1.8.11
PING 10.1.8.11 (10.1.8.11) 56(84) bytes of data:
64 bytes from 10.1.8.11: icmp_seq=1 ttl=60 time=0.801 ms
64 bytes from 10.1.8.11: icmp_seq=2 ttl=60 time=0.842 ms
64 bytes from 10.1.8.11: icmp_seq=3 ttl=60 time=0.836 ms
64 bytes from 10.1.8.11: icmp_seq=4 ttl=60 time=0.744 ms
64 bytes from 10.1.8.11: icmp_seq=5 ttl=60 time=0.782 ms

```





## 2. Configure Layer 2 Out Domain

- **Fabric > Access Policies > Physical & External Domain > External Bridged Domain > Right – click > Create External Bridged Domain**
- Enter these parameters:
  - Name : **UserX-L2OutDom1**
  - VLAN Pool : **UserX-Static-VLANs-1**
- Click **Submit**

## 3. Configure AAEP

- **Fabric > Access Policies > Policies > Global > Right – Click Attachable Access Entity Profile > Create Attachable Access Entity Profile**
- Enter these parameters:
  - Name : **UserX-L2OutDom-AAEP**
- Click + On Domain VMM, Physical or External to be associated to interfaces:
  - Domain Profile : **UserX-L2OutDom1**
- Click **Update > Next > Finish**

## 4. Configure Access Port Policy Group

[Leaf Access Port Connected to UserX-Switch Gi1/0/22](#)

- **Fabric > Access Policies > Interface > Leaf Interfaces > Policy Group > Right Click Leaf Access Port > Create Leaf Access Port Policy Group**
- Enter these parameters:
  - Name : **UserX- L2OUT\_AP\_PG**
  - CDP : **UserX-CDP-ON**
  - LLDP : **UserX-LLDP-ON**
  - Link Level : **UserX-1G-ON**
  - AAEP : **UserX-L2OutDom-AAEP**
- Click **Submit**

## 5. Configure Interface Policy Group on Existing Access Port Interface Selector

[Interface Selector for Access Port Interface from Leaf 102 Connected to UserX-Switch Interface Gi1/0/22](#)

- **Fabric > Access Policies > Interface > Leaf Interfaces > Profiles > UserX-LF102-IPF > L102\_Eth1-37 > Interface Policy Group**

- Selector: **L102\_Eth1-37**
  - Interface Policy Group : **UserX-L2OUT\_AP\_PG**
- Click **Submit**

## 6. Configure Layer 2 Out

- **Tenant > UserX-Prod > Networking > Right Click on L2Outs > Create L2Outs >**
- Enter these parameters:
  - Name : **GCTX\_Trad\_Switch\_VLAN\_Y\_L2OUT**
  - External Bridged Domain : **UserX-L2OutDom1**
  - Bridged Domain : **GCTX\_Prod\_DB\_BD**
  - Encap VLAN : **Y**
  - Path Type : **Port**
  - Node : **DC1-LEAF-102**
  - Path : **Eth1/37**
- Click **Add > Next > Click + On External EPG Networks**
- Enter these parameters:
  - Name : **GCTX\_Trad\_Switch\_VLAN\_Y\_L2OUT\_EPG**
- Click **OK**

## 7. Configure Contract

[Configure Contract to allow communication from GCTX\\_Prod\\_DB\\_EPG to : GCTX\\_Trad\\_Switch\\_VLAN\\_Y\\_L2OUT\\_EPG](#)

- **Tenant > UserX-Prod > Contracts > Standard > Right-Click > Create Contract**
- Contract 1:
  - Contract Name : **GCTX\_Prod\_DB\_to\_Trad\_DB**
  - Subject Name : **GCTX\_Prod\_DB\_to\_Trad\_DB**
  - Filter:
    - Name : **GCTX-Permit-All**
    - Ethertype : **unspecified**
    - Source Port/Range : **unspecified/unspecified**
    - Destination Port/Range : **unspecified/unspecified**
- Click **Submit**

## 8. Associate Contract to EPGs

Configure Contract to allow communication from GCTX\_Prod\_DB\_EPG to :  
GCTX\_Trad\_Switch\_VLAN\_Y\_L2OUT\_EPG

- **Tenant > UserX-Prod > Application Profiles > GCTX\_Prod\_AP > Application EPGs > GCTX\_Prod\_DB\_EPG > Contract > Right-Click > Add Consumed Contract**
- Select these parameters:
  - Contract Name : **GCTX\_Prod\_DB\_to\_Trading\_DB**
- Click **Submit**

- 
- **Tenant > UserX-Prod > Networking > L2Outs > GCTX\_Trad\_Switch\_L2OUT > External EPGs > GCTX\_Trad\_Switch\_L2OUT\_EPG > Contracts > Click + On Provided Contracts**
  - Select these parameters:
    - Contract Name : **GCTX\_Prod\_DB\_to\_Trading\_DB**
  - Click **Update**

## 9. Configure Subnet on Bridge Domain

Configure Subnet On GCTX\_Prod\_DB\_BD to Move VM Gateway to Cisco ACI Leaves

- **Tenant > UserX-Prod > Networking > Bridge Domain > GCTX\_Prod\_DB\_BD Policy > L3 Configuration > Click on Subnet**
- Modify these parameters:
  - Forwarding : **Optimize**
  - Unicast Routing : **Check**
  - Subnets/GW : **10.X.Y.1/24**
- Click **Submit**

# Cisco ACI VMM Integration Lab

## 1. Lab Topology

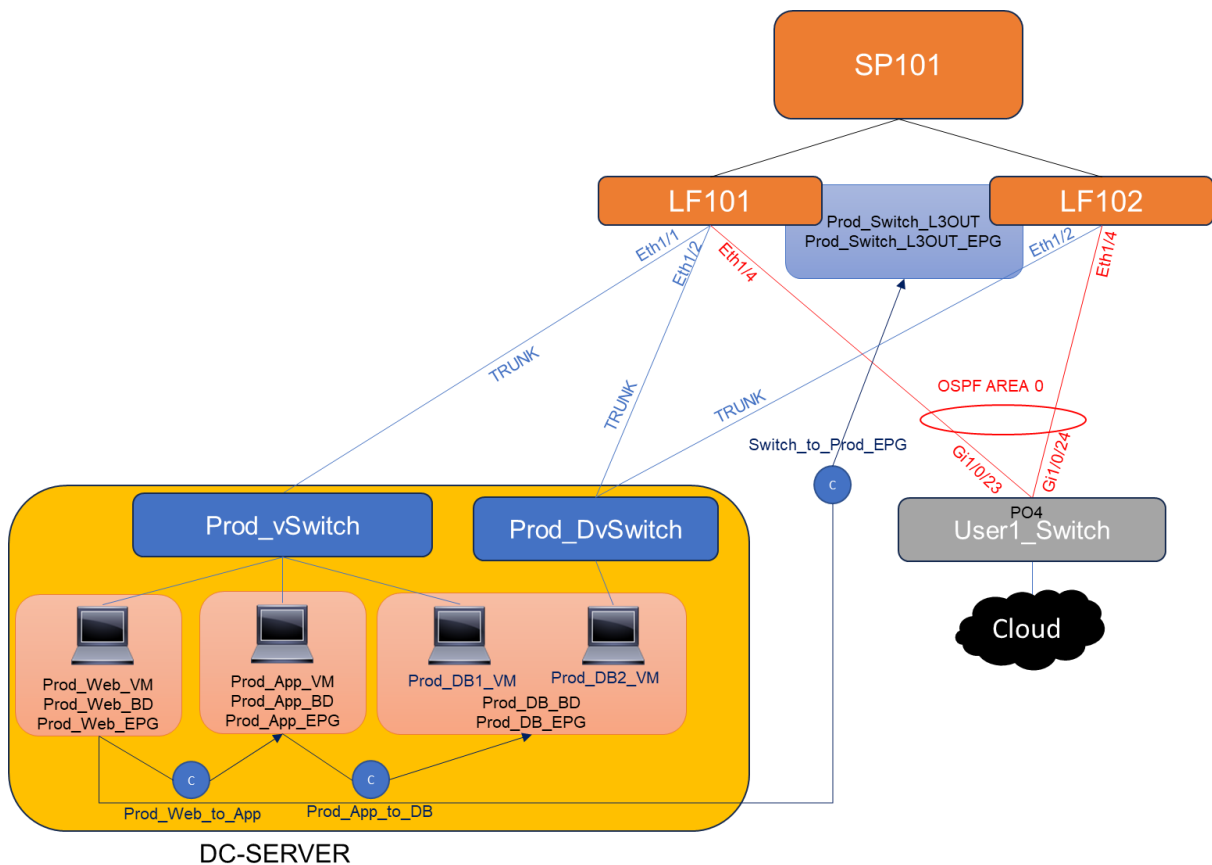

## 2. Configure & Verify VLAN Pool

- **Fabric > Access Policies > Pools > VLANs > User-Statics-VLANs-1 >**
- Verify these parameters:
  - Name : **UserX-VMM-VLANs-1**
  - Allocation Mode : **Dynamic Allocation**
  - Encap Block (Vlan Range) : **1901-2000**

## 3. Configure VMM Domain

- **Virtual Networking > VMware > Right Click on VMware > Create vCenter Domain**
- Enter these parameters:
  - Name : **UserX-VMM1**
  - Virtual Switch : **VMware vSphere Distributed Switch**
  - VLAN Pool : **UserX-VMM-VLANs-1**

#### 4. Configure AAEP

- Click **Dropdown on AAEP > Create Attachable Access Entity Profile**
- Enter these parameters:

- Name : **UserX-VMMDom-AAEP**

- Click **Next > Finish**

#### 5. Configure vCenter Credential

- Click **+ On vCenter Credential**
- Enter these parameters:

- Name : **UserX-vCenter-Credential**
- Username : **[administrator@UserX.local](#)**
- Password : **\*\*\*\*\***
- Confirm Password : **\*\*\*\*\***

- Click **OK**

#### 6. Configure vCenter

- Click **+ On vCenter**
- Enter these parameters:

- Name : **UserX-vCenter**
- Hostname : **192.168.X.170**
- Data Center : **DC1**
- Associated Credential : **UserX-vCenter-Credential**

- Click **OK**

#### 7. Configure vSwitch

- Enter these parameters:

- Number Of Uplink : **2**
- Port Channel Policy : **MAC-Pinning +**
- vSwitch Policy : **CDP**

- Click **Submit**

## 8. Configure Access Port Policy Group

[Leaf Access Port Connected to DC1-SERVER ESXi vmnic4 & vmnic5](#)

- **Fabric > Access Policies > Interface > Leaf Interfaces > Policy Group > Right Click Leaf Access Port > Create Leaf Access Port Policy Group**
- Enter these parameters:
  - Name : **UserX- VMM\_AP\_PG**
  - CDP : **UserX-CDP-ON**
  - LLDP : **UserX-LLDP-ON**
  - Link Level : **UserX-1G-ON**
  - AAEP : **UserX-VMMDom-AAEP**
- Click **Submit**

## 9. Configure Access Port Interface Selector

[Interface Selector for Access Port Interface from Leaf 101 Connected to DC1-SERVER ESXi vmnic4](#)

- **Fabric > Access Policies > Interface > Leaf Interfaces > Profiles > UserX-LF101-IPF > Click + on Interface Selector**
- Selector:
  - Name : **L101\_Eth1-38**
  - Description : **Connected to DC1-SERVER vmnic4**
  - Interface ID : **1/38**
  - Interface Policy Group : **UserX-VMM\_AP\_PG**
- Click **Submit**

-----  
[Interface Selector for Access Port Interface from Leaf 102 Connected to DC1-SERVER ESXi vmnic5](#)

- **Fabric > Access Policies > Interface > Leaf Interfaces > Profiles > UserX-LF102-IPF > Click + on Interface Selector**
- Selector:
  - Name : **L102\_Eth1-38**
  - Description : **Connected to DC1-SERVER vmnic5**
  - Interface ID : **1/38**
  - Interface Policy Group : **UserX-VMM\_AP\_PG**
- Click **Submit**

## 10. Configure VMM Domain On EPG

### Configure VMM Domain On EPGs to Push Port Group to vCenter

- **Tenant > UserX-Prod > Application Profiles > GCTX\_Prod\_AP > Application EPGs > <EPG Name> Domain > Right-Click > click Add VMM Domain Association**
- Endpoint Group 1:
  - Application EPG : **GCTX\_Prod\_Web\_EPG**
  - Domain : **UserX-VMMDom1**
- Click **Submit**

---

- Endpoint Group 2:
  - Name : **GCTX\_Prod\_App\_EPG**
  - Domain : **UserX-VMMDom1**
- Click **Submit**

---

- Endpoint Group 3:
  - Name : **GCTX\_Prod\_DB\_EPG**
  - Domain : **UserX-VMMDom1**
- Click **Submit**

## Cisco ACI VRF Route Leaking Lab

### 1. Lab Topology

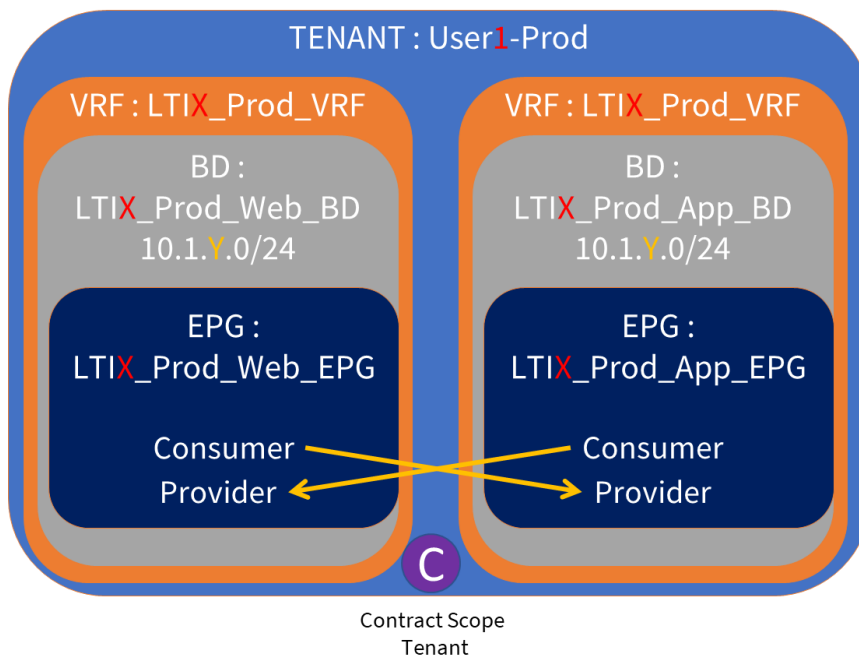

## 2. Leaking Scenario

From EPG	From VRF	To EPG	To VRF	Contract Name
GCT1_Prod_Web_EPG	GCT1_Prod_VRF	GCT2_Prod_App_EPG	GCT2_Prod_VRF	GCT12_Web_to_App_Inter_VRF
GCT2_Prod_Web_EPG	GCT2_Prod_VRF	GCT1_Prod_App_EPG	GCT1_Prod_VRF	GCT21_Web_to_App_Inter_VRF
GCT3_Prod_Web_EPG	GCT3_Prod_VRF	GCT4_Prod_App_EPG	GCT4_Prod_VRF	GCT34_Web_to_App_Inter_VRF
GCT4_Prod_Web_EPG	GCT4_Prod_VRF	GCT3_Prod_App_EPG	GCT3_Prod_VRF	GCT43_Web_to_App_Inter_VRF
GCT5_Prod_Web_EPG	GCT5_Prod_VRF	GCT1_Prod_App_EPG	GCT1_Prod_VRF	GCT51_Web_to_App_Inter_VRF
GCT1_Prod_Web_EPG	GCT1_Prod_VRF	GCT5_Prod_App_EPG	GCT5_Prod_VRF	GCT15_Web_to_App_Inter_VRF

## 3. Modify Bridge Domain Configuration

[Configure Bridge Domain to leak subnets between VRFs \(GCT1 <> GCT2, GCT3 <> GCT4, GCT5 <> GCT6\)](#)

- **Tenant > UserX-Prod > Networking > Bridge Domain > <BD Name> Policy > L3 Configuration > Click on Subnet**
- **GCTX\_Prod\_Web\_BD:**
  - Scope : **Shared Between VRF**
- Click **Submit**
- 
- **GCTX\_Prod\_App\_BD:**
  - Scope : **Shared Between VRF**
- Click **Submit**

## 4. Configure Contract

[Configure Contract to allow communication from GCTX\\_Prod\\_Web\\_EPG to GCTX\\_Prod\\_App\\_EPG on different VRFs](#)

- **Tenant > UserX-Prod > Contracts > Standard > Right-Click > Create Contract**
- Contract 1:
  - Contract Name : **GCTXX\_Web\_to\_App\_Inter\_VRF**
  - Scope : **Tenant**
  - Subject Name : **GCTXX\_Web\_to\_App\_Inter\_VRF**
  - Filter:
    - Name : **GCTXX-Permit-All**
    - Ethertype : **unspecified**
    - Source Port/Range : **unspecified/unspecified**
    - Destination Port/Range : **unspecified/unspecified**
- Click **Submit**

## 5. Associate Contract to EPGs

[Associate Contract to EPGs to allow communication from GCTX\\_Prod\\_Web\\_EPG to GCTX\\_Prod\\_App\\_EPG on different VRFs](#)

- **Tenant > UserX-Prod> Application Profiles > GCTX\_Prod\_AP > Application EPGs > GCTX\_Prod\_Web\_EPG > Contract > Right-Click > Add Consumed Contract**
  - Select these parameters:
    - Contract Name : **GCTXX\_Web\_to\_App\_Inter\_VRF**
  - Click **Submit**
- 
- **Tenant > UserX-Prod> Application Profiles > GCTX\_Prod\_AP > Application EPGs > GCTX\_Prod\_App\_EPG > Contract > Right-Click > Add Provided Contract**
  - Select these parameters:
    - Contract Name : **GCTXX\_Web\_to\_App\_Inter\_VRF**
  - Click **Submit**

## Cisco ACI Transit Routing VRF Route Leaking Lab

### 1. Lab Topology

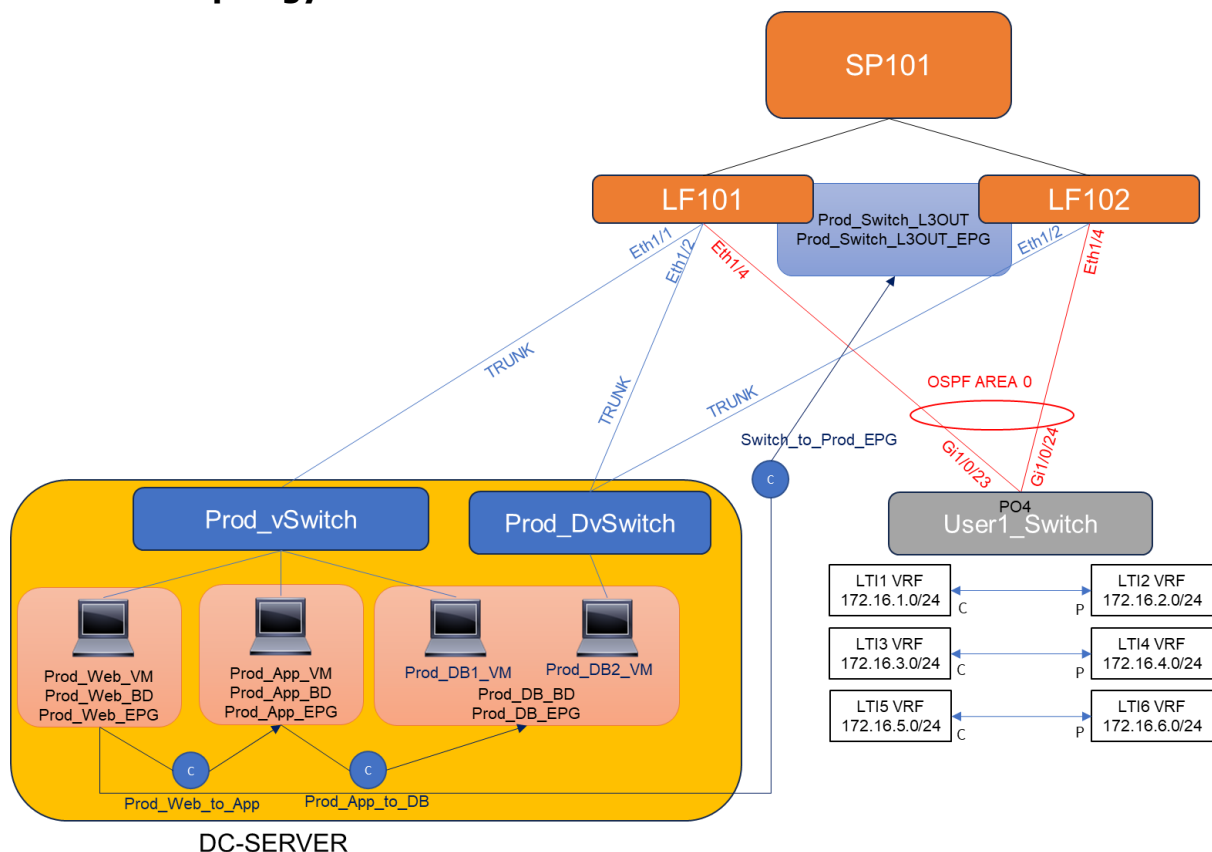

## 2. Configure L3Out External EPG

[Configure L3Out External EPG to import subnet from UserX-Switch prefix on different VRF](#)

- **Tenant > UserX-Prod > Networking > L3Outs > GCTX-Prod\_Switch\_L3Out > External EPGs > GCTX-Prod\_Switch\_L3Out\_EPG > Click + On Subnet**
- Enter these parameters:
  - IP Address : **172.16.Y.0/24**
  - Shared Route Control Subnet : **Checked**
  - Shared Security Import Subnet : **Checked**
  - External Subnet For External EPG : **Checked**
- Click **Submit**

-----  
[Configure L3Out External EPG to export subnet into UserX-Switch prefix on different VRF](#)

- **Tenant > UserX-Prod > Networking > L3Outs > GCTX-Prod\_Switch\_L3Out > External EPGs > GCTX-Prod\_Switch\_L3Out\_EPG > Click + On Subnet**
- Enter these parameters:
  - IP Address : **172.16.Y.0/24**
  - Export Route Control Subnet : **Checked**
- Click **Submit**

## 3. Configure Contract

[Configure Contract to allow communication from GCTX Trad Switch L3OUT to GCTX Trad Switch L3OUT on different VRFs](#)

- **Tenant > UserX-Prod > Contracts > Standard > Right-Click > Create Contract**
- Contract 1:
  - Contract Name : **GCTXX\_L3OUT\_to\_L3OUT\_Inter\_VRF**
  - Scope : **Tenant**
  - Subject Name : **GCTXX\_L3OUT\_to\_L3OUT\_Inter\_VRF**
  - Filter:
    - Name : **GCTXX-Permit-All**
    - Ethertype : **unspecified**
    - Source Port/Range : **unspecified/unspecified**
    - Destination Port/Range : **unspecified/unspecified**
- Click **Submit**

## 4. Associate Contract to L3Out External EPG

[Associate Contract to allow communication from GCTX Trad Switch L3OUT to GCTX Trad Switch L3OUT on different VRFs](#)

- **Tenant > UserX-Prod > Networking > L3Outs > GCTX-Prod\_Switch\_L3Out > External EPGs > GCTX-Prod\_Switch\_L3Out\_EPG > Contract > Add Consumed Contract**
- Select these parameters:
  - Contract Name : **GCTX\_L3OUT\_to\_L3OUT\_Inter\_VRF**
- Click **Submit**

---

- **Tenant > UserX-Prod > Networking > L3Outs > GCTX-Prod\_Switch\_L3Out > External EPGs > GCTX-Prod\_Switch\_L3Out\_EPG > Contract > Add Provided Contract**
- Select these parameters:
  - Contract Name : **GCTX\_L3OUT\_to\_L3OUT\_Inter\_VRF**
- Click **Submit**

## Cisco ACI vzAny Contract Lab

### 1. Configure Contract

[Configure new contract for vzany](#)

- **Tenant > UserX-Prod > Contracts > Standard > Right-Click > Create Contract**
- Contract 1:
  - Contract Name : **GCTX\_VZANY**
  - Subject Name : **GCTX\_VZANY**
  - Filter:
    - Name : **GCTX-Permit-All**
    - Ethertype : **unspecified**
    - Source Port/Range : **unspecified/unspecified**
    - Destination Port/Range : **unspecified/unspecified**
- Click **Submit**

## 2. Remove Associated Contract from EPGs

Remove Associated Contract from EPGs and we will use vzany for contract relation

- **Tenant > UserX-Prod> Application Profiles > GCTX\_Prod\_AP > Application EPGs > GCTX\_Prod\_Web\_EPG > Contract > Right-Click GCTX\_Web\_to\_App**
- Click **Delete**

---

- **Tenant > UserX-Prod> Application Profiles > GCTX\_Prod\_AP > Application EPGs > GCTX\_Prod\_App\_EPG > Contract > Right-Click GCTX\_Web\_to\_App**
- Click **Delete**

---

- **Tenant > UserX-Prod> Application Profiles > GCTX\_Prod\_AP > Application EPGs > GCTX\_Prod\_App\_EPG > Contract > Right-Click GCTX\_App\_to\_DB**
- Click **Delete**

---

- **Tenant > UserX-Prod> Application Profiles > GCTX\_Prod\_AP > Application EPGs > GCTX\_Prod\_DB\_EPG > Contract > Right-Click GCTX\_App\_to\_DB**
- Click **Delete**

## 3. Configure vzAny Contract Relation

- **Tenant > UserX-Prod> Networking > VRFs > GCTX\_VRF > EPG Collection for VRF > Click + On Provided Contract**
- Select the Contract:
  - Contract Name : **GCTX\_VZANY**
- Click **Update**

---

- **Tenant > UserX-Prod> Networking > VRFs > GCTX\_VRF > EPG Collection for VRF > Click + On Consumed Contract**
- Select the Contract :
  - Contract Name : **GCTX\_VZANY**
- Click **Update**

# Cisco ACI Service Graph PBR One Arm Mode Lab

## 1. Lab Topology

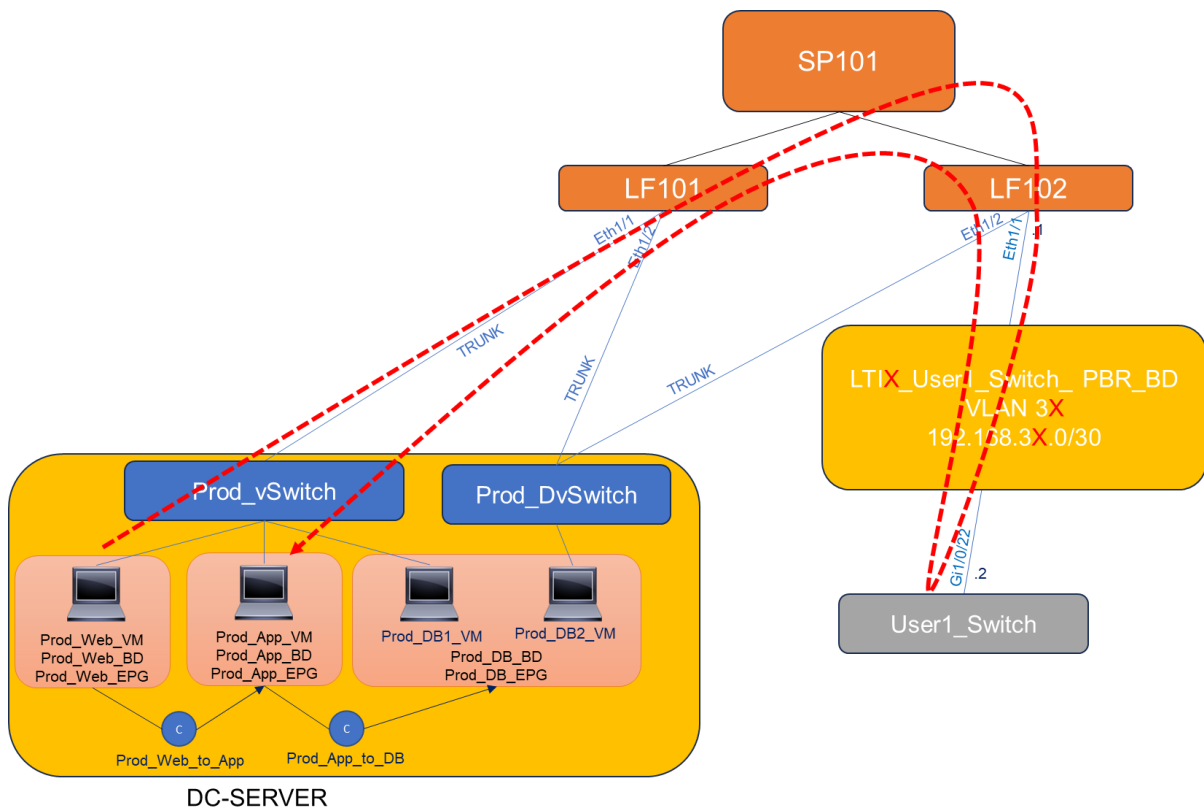

## 2. Configure & Verify VLAN Pool

- **Fabric > Access Policies > Pools > VLANs > User-Statics-VLANs-3 >**
- Verify these parameters:
  - Name : **UserX-Static-VLANs-3**
  - Allocation Mode : **Static Allocation**
  - Encap Block (Vlan Range) : **31-40**

## 3. Configure Physical Domain

- **Fabric > Access Policies > Physical & External Domain > Physical Domain > Right – click > Create Physical Domain**
- Enter these parameters:
  - Name : **UserX-PhysDom3**
  - VLAN Pool : **UserX-Static-VLANs-3**
- Click **Submit**

#### 4. Configure Domain on Existing AAEP

- **Fabric > Access Policies > Policies > Global > Attachable Access Entity Profile > UserX-PhysDom-AAEP**
- Click + On Domain VMM, Physical or External to be associated to interfaces:
  - Domain Profile : **UserX-Physdom3**
- Click **Update**

#### 5. Modify Existing Access Port Interface Selector

[Interface Selector for Access Port Interface from Leaf 102 Connected to UserX-Switch Interface Gi1/0/22](#)

- **Fabric > Access Policies > Interface > Leaf Interfaces > Profiles > UserX-LF102-IPF > L102\_Eth1-1**
- Selector:
  - Interface Policy Group : **UserX-1G\_AP\_PG**
- Click **Submit**

#### 6. Configure Bridge Domain For PBR

[Configure L3 Bridge Domain For P2P Connection Between UserX-Switch & Leaves](#)

- **Tenant > UserX-Prod > Networking > Right-Click Bridge Domain > Create Bridge Domain**
- Bridge Domain:
  - Name : **GCTX\_PBR\_UserX-SW\_BD**
  - VRF : **GCTX\_Prod\_VRF**
  - Subnets/GW : **192.168.3X.1/30**
- Click **Submit**

#### 7. Configure L4-L7 Redirect Policy

- **Tenant > UserX-Prod > Policies > Protocol > Right Click L4-L7 Policy Based Redirect > Create L4-L7 Policy Based Redirect**
- Enter these parameters:
  - Name : **GCTX\_PBR\_UserX-SW\_Policy**
- Click + On L3 Destination:
  - IP : **192.168.3X.2**
  - MAC : **UserX-Switch Interface VLAN 3X Mac Address**
- Click **Submit**

## 8. Configure L4-L7 Devices

- **Tenant > UserX-Prod > Services > L4-L7 > Right Click Devices > Create L4-L7 Devices**
- Enter these parameters:
  - Name : **GCTX\_PBR\_UserX-SW**
  - Service Type : **Other**
  - Device Type : **Physical**
  - Physical Domain : **UserX-PhysDom3**
  - Function Type : **GoTo**
- Concrete Device:
  - Device Name : **GCTX\_PBR\_UserX-SW**
  - Interface Name : **GCTX\_PBR\_UserX-SW\_INTF**
  - Path : **102/Eth1-1**
- Cluster Interface:
  - Name : **GCTX\_prod\_pbr**
  - Concrete Interface : **102/Eth1-1**
  - Name : **GCTX\_prod\_pbr**
  - Vlan : **vlan-3X**
- Click **Submit**

## 9. Configure L4-L7 Service Graph Template

- **Tenant > UserX-Prod > Services > L4-L7 > Right Click Service Graph Template > Create L4-L7 Service Graph Template**
- Enter these parameters:
  - Service Graph Name : **GCTX\_PBR\_UserX-SW\_SG**
  - Device : **GCTX\_PBR\_UserX-SW**
  - Function Node Name : **GCTX\_PBR**
  - Route Redirect : **True/Checked**
- Click **Submit**

## 10. Configure L4-L7 Device Selection Policy

- **Tenant > UserX-Prod > Services > L4-L7 > Right Click Devices Selection Policies > Create Logical Device Context**
- Enter/Select these parameters:
  - Contract Name : **GCTX\_VZANY**
  - Graph Name : **GCTX\_PBR\_UserX-SW\_SG**
  - Node Name : **GCTX\_PBR\_UserX-SW**
  - Device : **GCTX\_PBR\_UserX-SW**

- Click + On Cluster Interface Context & Enter these parameters:
  - Connector Name : consumer
  - Cluster Interface : **GCTX\_prod\_pbr**
  - Associated Bridge Domain : **GCTX\_PBR\_UserX-SW\_BD**
  - L4-L7 Policy Based Redirect : **GCTX\_PBR\_UserX-SW\_Policy**

- Click **OK**

- 
- Click + On Cluster Interface Context & Enter these parameters:
    - Connector Name : provider
    - Cluster Interface : **GCTX\_prod\_pbr**
    - Associated Bridge Domain : **GCTX\_PBR\_UserX-SW\_BD**
    - L4-L7 Policy Based Redirect : **GCTX\_PBR\_UserX-SW\_Policy**

- Click **OK** & Click **Submit**

## **11. Associate Service Graph Policy to Contract Subject**

- **Tenant > UserX-Prod > Contract > Standard > GCTX\_VZANY > Subject > GCTX\_VZANY > Click on L4-L7 Service Graph**

- Select parameters:
  - Service Graph Name : **GCTX\_PBR\_UserX-SW\_SG**

- Click **Submit**